

PERM-A-BARRIER[®] Wall Membrane

Self-adhesive, rubberized asphalt/polyethylene waterproofing membrane for air and vapor barrier applications

Product Description

PERM-A-BARRIER[®] Wall Membranes are ideal for protecting the building superstructure from the damaging effects of the elements. By minimizing air and water vapor flow through the building exterior, Perm-A-Barrier Wall Membranes:

- Prevent premature deterioration of the building envelope
- Enhance thermal performance of the structure and save energy costs
- Improve comfort for the building occupants

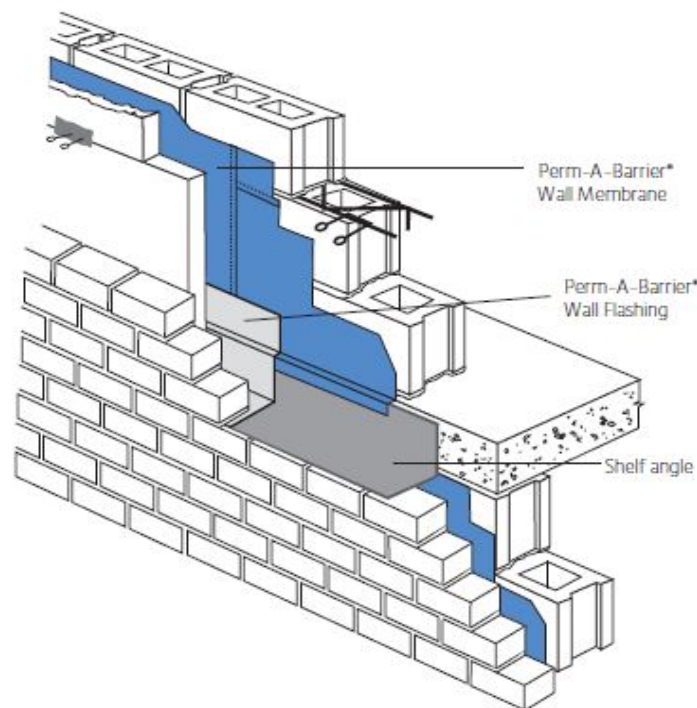

Product Advantages

- Fully bonded - transmits wind loads directly to the substrate
- Waterproof and impermeable to moisture - impermeable to the passage of liquid water and water vapor
- Air tight - protects against air passage and associated energy losses. Meets new ASTM E2357 standard as required by IECC 2012
- Cross laminated film - provides dimensional stability, high tear strength, puncture and impact resistance
- Cold applied - no flame hazard; self-adhesive overlaps ensure continuity

- **Flexible** – accommodates minor settlement and shrinkage movement
- **Controlled thickness** – factory made sheet ensures constant, non-variable site application
- **Aggressive, conformable adhesive** – allows self-sealing around mechanical fasteners
- **Wide application window** –
 - PERM-A-BARRIER® Wall Membrane surface and ambient temperatures at 5°C (40°F) and above
 - PERM-A-BARRIER® Low Temperature Wall Membrane surface and ambient temperatures between 25°F (-4°C) and 60°F (16°C)
 - PERM-A-BARRIER® High Temperature Wall Membrane for use at in-service temperatures between 150°F (65°C) and 180°F (82°C)

System Components

- **PERM-A-BARRIER® Wall Membrane** – standard grade for use at installation temperatures above 40°F (5°C)
- **PERM-A-BARRIER® Low Temperature Wall Membrane** – low temperature grade for use at installation temperatures between 25°F (-4°C) and 60°F (16°C)
- **PERM-A-BARRIER® High Temperature Wall Membrane** – for use where in-service temperatures are between 150°F (65°C) and 180°F (82°C)
- **PERM-A-BARRIER® Primer Plus** – water-based vapor permeable primer used to facilitate tenacious adhesion of Perm-A-Barrier self-adhered membranes to the substrate
- **PERM-A-BARRIER® WB Primer** – high tack, water-based primer for use with Perm-A-Barrier Wall Membranes on cementitious and exterior gypsum wallboards
- **BITUTHENE® Primer B2 LVC** – low VOC primer for priming green concrete and damp surfaces
- **S100 Sealant** – one part neutral curing, ultra low modulus silicone sealant for sealing penetrations, terminations, brick ties and final terminations
- **BITUTHENE® Mastic** – rubberized asphalt mastic for sealing penetrations, terminations, brick ties, etc.
- **BITUTHENE® Liquid Membrane** – two component, trowel grade, asphalt modified urethane for sealing patches, terminations, brick ties, etc.
- **PERM-A-BARRIER® Wall Flashing** – fully adhered through wall flashing system
- **PERM-A-BARRIER® Detail Membrane** – fully adhered flashing for protecting and sealing critical detail areas

Installation

Safety

PERM-A-BARRIER® products must be handled properly. Vapors from the mastic and solvent-based primer are harmful and flammable. For these products, the best available information on safe handling, storage, personal protection, health and environmental considerations has been gathered. Refer to product label and Safety Data Sheet before use. All users should acquaint themselves with this information prior to working with the material. Carefully read detailed precaution statements on the product labels and SDS before use. SDSs can be obtained from our web site at gcpat.com or by contacting us toll free at 866-333-3SBM (3726).

Surface Preparation

Surface must be smooth, clean, dry and free of voids, spalled areas, loose aggregate, loose nails, sharp protrusions or other matter that will hinder the adhesion or regularity of the wall membrane installation. Clean loose dust or dirt from the surface to which the wall membrane is to be applied by wiping with a clean, dry cloth or brush.

If the substrate is damp, allow to dry or use BITUTHENE® Primer B2 LVC to prepare the area to receive the membrane.

Temperature

PERM-A-BARRIER® Low Temperature Membrane may be applied only in dry weather when air and surface temperatures are between 25°F (-4°C) and 60°F (16°C). PERM-A-BARRIER® Wall Membrane and PERM-A-BARRIER® High Temperature Wall Membrane may be applied only in dry weather when air and surface temperatures are above 40°F (5°C).

Application

PERM-A-BARRIER® Primer Plus and PERM-A-BARRIER® WB Primer are water-based primers which impart an aggressive, high tack finish on the treated substrate. They are packaged ready to use and are specifically designed to facilitate tenacious adhesion of PERM-A-BARRIER® Wall Membranes to various substrates including glass-mat faced gypsum sheathing. Refer to Technical Letter 2, *Substrate Preparation for Application of Perm-A-Barrier Products to GlassMat Faced Gypsum Sheathing* for priming requirements on specific glass-mat faced sheathing products.

Membrane Application

Cut membrane into easily handled lengths. Apply membrane horizontally or vertically to primed substrates receiving post-applied masonry anchors (ties), such as gypsum sheathing.

Apply PERM-A-BARRIER® Wall Membranes horizontally to the primed blockwork with projecting masonry anchors (ties), beginning at the base of the wall. Each length of the membrane must be installed so that the upper edge runs continuously along the underside of the line of masonry anchors (ties). Subsequent sheets applied above must overlap the sheet below by 2 in. (51 mm) immediately below the line of anchors (ties). Since the membrane width appropriate for this application of 18 in. (457 mm) is wider than the typical spacing between the lines of anchors (ties) 16 in. (406 mm), it will be necessary to cut the membrane at the location of the tie wires projecting from the wall to enable the sheet to be laid in place. End laps that occur in subsequent lengths that follow should maintain a minimum overlap of 2 in. (51 mm). See Figures 1 and 2.

The membrane must be pressed firmly into place with a hand roller or the back of a utility knife as soon as possible, ensuring continuous and intimate contact with the substrate to prevent water from migrating under the membrane.

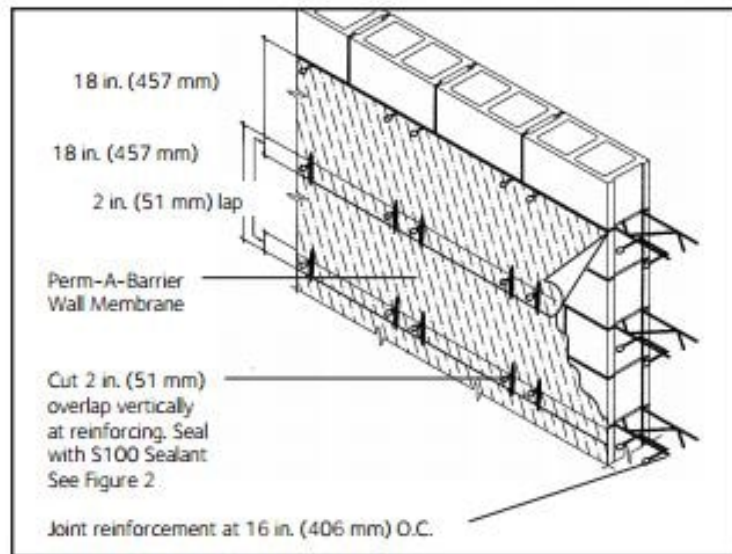

For PERM-A-BARRIER®High Temperature Wall Membrane, secure top edge of membrane with mechanical termination bar fastened securely into the structure.

In certain applications such as on soffits, ceilings or substrates such as oriented strand board (OSB), backnail the membrane along the side lap prior to installing the next sheet of membrane to ensure positive contact to the substrate. Additional fastening may be required through the field of the membrane in these applications and must be sealed with S100 Sealant, BITUTHENE®Liquid Membrane or BITUTHENE®Mastic.

Apply S100 Sealant, BITUTHENE®Mastic or BITUTHENE®Liquid Membrane to seal around the tie wire projections. Fit the PERM-A-BARRIER®Wall Membrane tightly around all penetrations through the membrane and seal using S100 Sealant, or BITUTHENE®Liquid Membrane.

Continue the membrane into all openings in the wall area, such as windows, doors, etc., and terminate at points that will prevent interior visibility. The installation must be made continuous at all framed openings. Coordinate installation of the Perm-A-Barrier Wall Membrane with the roofing trade to ensure continuity with the roofing system at this critical transition area.

At the end of each working day, if the wall has been only partially covered, apply a bead of BITUTHENE®Mastic or BITUTHENE®Liquid Membrane along the top edge of the membrane at its termination to prevent vertical drainage of precipitation from penetrating the end and undermining the membrane adhesion. Tool the BITUTHENE®Mastic or BITUTHENE®Liquid Membrane to ensure it is worked into the surface. For final terminations that will not be covered with membrane, S100 Sealant can be used in lieu of BITUTHENE®Mastic or BITUTHENE®Liquid Membrane. Inspect the membrane before covering and repair any punctures, damaged areas or inadequately lapped seams.

All non water shedding edges must be sealed with S100 Sealant, BITUTHENE®Liquid Membrane or BITUTHENE®Mastic.

Membrane Repairs

Repairs must be made using PERM-A-BARRIER® Wall Membrane sized to extend 6 in. (150 mm) in all directions from the perimeter of the affected area. The repair piece must be pressed into place with a hand roller as soon as possible to ensure continuous and intimate contact with the substrate.

Membrane Protection

PERM-A-BARRIER® Wall Membranes must be protected from damage by other trades or construction materials.

Storage and Handling Information

All materials must be protected from rain and physical damage. Pallets of PERM-A-BARRIER® Wall Membrane must not be double stacked on the job site. Provide cover on top and all sides, allowing for adequate ventilation. Store membrane where temperatures will not exceed 90 °F (32 °C) for extended periods. All products must be stored in a dry area away from high heat, flames or sparks. Store only as much material at point of use as is required for each day's work.

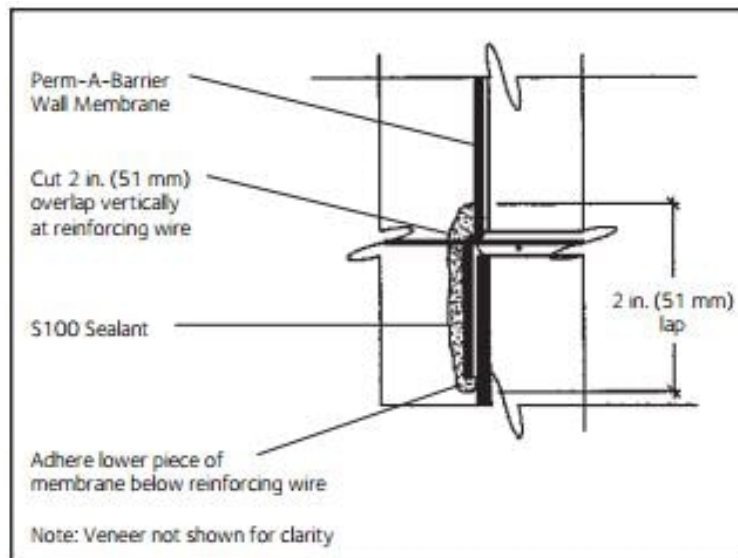

Limitations

PERM-A-BARRIER® Wall Membrane systems must not be applied in areas where they will be permanently exposed to UV light and must be covered within a reasonable amount of time, not to exceed 60 days. Refer to Technical Letter 19, *Exposure Guidelines for PERM-A-BARRIER® Self-Adhered Membranes*.

PERM-A-BARRIER® Wall Membrane Systems and all other PERM-A-BARRIER® self-adhered membranes should not be applied over S100 Sealant.

Warranty

PERM-A-BARRIER® products are warranted to be free of defects in manufacture for a period of 5 years. Material will be provided at no charge to replace any defective product.

Technical Service

Support is provided by full-time technically trained GCP field sales representatives and technical service personnel, backed by a central research and development technical services staff.

Supply

1	UNIT OF SALE	APPROXIMATE COVERAGE	WEIGHT	PALLETIZATION
PERM-A-BARRIER® Wall Membranes	1 roll	225 ft ² (20.9 m ²) per roll 3 x 75 ft (0.9 x 25 m) roll	67 lbs/roll	25 cartons (25 rolls) per pallet
PERM-A-BARRIER® Wall Flashing				
12 in. (305 mm)	3 rolls	75 linear ft per roll	25 lbs/roll	25 cartons (75 rolls) per pallet
18 in. (457 mm)	2 rolls	75 linear ft per roll	37.5 lbs/roll	25 cartons (50 rolls) per pallet
24 in. (610 mm)	1 roll	75 linear ft per roll	55 lbs/roll	35 cartons (35 rolls) per pallet
36 in. (914 mm)	1 roll	75 linear ft per roll	75 lbs/roll	25 cartons (25 rolls) per pallet
PERM-A-BARRIER® Detail Membrane				
6 in. (152 mm)	6 rolls	75 linear ft per roll	11 lbs/roll	25 cartons (150 rolls) per pallet
9 in. (225 mm)	4 rolls	75 linear ft per roll	16 lbs/roll	25 cartons (100 rolls) per pallet
12 in. (305 mm)	3 rolls	75 linear ft per roll	22 lbs/roll	25 cartons (75 rolls) per pallet
BITUTHENE® Mastic – 5 gal pail	1 pail	approx. 120 ft ² at 60 mils	54 lbs/pail	36 pails per pallet
BITUTHENE® Mastic – 30 oz tube	12 tubes	approx. 30 linear ft x 1/4 in. bead	32 lbs/carton	72 cartons (864 tubes) per pallet
S100 Sealant – 29 oz. Cartridge	1 cartridge	approx. 30 linear ft x 1/4 in. bead	29 oz.	10 cartridges/ carton 42 cartons/ pallet
BITUTHENE® Liquid Membrane – 1.5 gal pail	1 pail	approx. 200 Linear ft/gal @ 1" wide x 90 mils.	16 lbs/pail	100 pails per pallet

BITUTHENE® Liquid Membrane - 4 gal pail	1 pail	approx. 200 Linear ft/gal @ 1" wide x 90 mils.	44 lbs/pail	24 pails per pallet
PERM-A-BARRIER® Primer Plus - 5 gal pail	1 pail	450-500 ft ² /gal (11-12 m ² /L)	43 lbs/pail	36 pails per pallet
PERM-A-BARRIER® WB Primer 1 - 5 gal pail	1 pail	250-350 ft ² /gal (6-8 m ² /L)	45 lbs/pail	32 pails per pallet
BITUTHENE® Primer B2 LVC - 5 gal pail	1 pail	325-425 ft ² /gal (7.5-10 m ² /L)	44 lbs/pail	48 pails per pallet

Physical Properties

	PERM-A-BARRIER® WALL MEMBRANE	PERM-A-BARRIER® LOW TEMPERATURE	PERM-A-BARRIER® HIGH TEMPERATURE	TEST METHOD
Thickness	3/64 in. (1 mm)	3/64 in. (1 mm)	3/64 in. (1 mm)	ASTM D3767 method A
Minimum tensile strength, membranes	400 psi (2.8 MPa)	400 psi (2.8 MPa)	400 psi (2.8 MPa)	ASTM D412 die C modified
Minimum tensile strength, film	5000 psi (34.5 MPa)	5000 psi (34.5 MPa)	5000 psi (34.5 MPa)	ASTM D412 die C modified
Minimum elongation, to failure of rubberized asphalt	200%	200%	200%	ASTM D412 die C modified
Pliability, at 180° bend over 1 in. (25 mm) mandrel	Pass at -25°F (-32°C)	Pass at -45°F (-43°C)	Pass at -25°F (-32°C)	ASTM D1970
Nail Sealability	Pass	Pass	Pass	ASTM D1970
Crack cycling, 1/8 in. (3.2 mm) at -25°F (-32°C)	Unaffected	Unaffected	Unaffected	ASTM C836
Minimum puncture resistance, membrane	40 lbs (178 N)	40 lbs (178 N)	40 lbs (178 N)	ASTM E154
Lap peel adhesion at minimum application temperature	4 lbs/in. width (700 N/m)	5 lbs/in. width (875 N/m)	4 lbs/in. width (700 N/m)	ASTM D1876 modified
Maximum permeance to water vapor transmission	0.05 perms/(Pa.s.m ²) (2.9 ng)	0.05 perms/(Pa.s.m ²) (2.9 ng)	0.05 perms/(Pa.s.m ²) (2.9 ng)	ASTM E96 method B
Air permeance of in-place membrane ¹	0.0002 cfm/ft ² (<0.001 L/s/m ²)	0.0002 cfm/ft ² (<0.001 L/s/m ²)	0.0002 cfm/ft ² (<0.001 L/s/m ²)	ASTM E2178
Assembly air permeance at 1.57 psf (75 Pa) pressure difference ²	<0.0008 cfm/ft ² (<0.004 L/s/m ²)	<0.0008 cfm/ft ² (<0.004 L/s/m ²)	<0.0008 cfm/ft ² (<0.004 L/s/m ²)	ASTM E2357
Air permeance of in-place membrane ³	No change in air permeance value	No change in air permeance value	No change in air permeance value	ASTM E330

Water absorption (weight gain
at 24 hours)

0.1%

0.1%

ASTM D570

Footnote:

1. Air permeance measured at a pressure differential of 1.57 psf (75 Pa).
2. Results below detectable limits of laboratory equipment.
3. Air permeance measured at a pressure differential of 1/64 in. (68 Pa) Hg after wall being subjected to a negative 57/64 in. (3014 Pa) Hg pressure difference for 10 seconds.

gcpat.com.au | Australia customer service: 1800 855 525

We hope the information here will be helpful. It is based on data and knowledge considered to be true and accurate, and is offered for consideration, investigation and verification by the user, but we do not warrant the results to be obtained. Please read all statements, recommendations, and suggestions in conjunction with our conditions of sale, which apply to all goods supplied by us. No statement, recommendation, or suggestion is intended for any use that would infringe any patent, copyright, or other third party right.

Perm-A-Barrier and Bituthene are trademarks, which may be registered in the United States and/or other countries, of GCP Applied Technologies Inc. This trademark list has been compiled using available published information as of the publication date and may not accurately reflect current trademark ownership or status.

© Copyright 2017 GCP Applied Technologies Inc. All rights reserved.

GCP Applied Technologies Inc., 2325 Lakeview Parkway, Alpharetta, GA 30009, USA

GCP Australia Pty. Ltd., 14 Colebard Street West, Archerfield, Brisbane, Queensland 4108, Australia

This document is only current as of the last updated date stated below and is valid only for use in Australia. It is important that you always refer to the currently available information at the URL below to provide the most current product information at the time of use. Additional literature such as Contractor Manuals, Technical Bulletins, Detail Drawings and detailing recommendations and other relevant documents are also available on www.gcpat.com.au. Information found on other websites must not be relied upon, as they may not be up-to-date or applicable to the conditions in your location and we do not accept any responsibility for their content. If there are any conflicts or if you need more information, please contact GCP Customer Service.

Last Updated: 2025-05-13

gcpat.com.au/solutions/products/perm-a-barrier-air-barrier-system/perm-a-barrier-wall-membrane