

Preprufe® 300R & 160R

Pre-applied waterproofing membranes that bond integrally to poured concrete for use below slabs or behind basement walls on confined sites

Product Description

Preprufe® 300R & 160R membranes are unique composite sheets comprising a thick HDPE film, an aggressive, pressure-sensitive adhesive and a weather-resistant protective coating. Unlike conventional non-adhering membranes, which are vulnerable to water ingress tracking between the unbonded membrane and structure, the unique Preprufe seal to concrete prevents any ingress or migration of water around the structure.

Product Advantages

- Forms a unique, integral seal to concrete poured against it. This prevents water migration and makes it unaffected by ground settlement beneath slabs.
- Fully-adhered watertight laps and detailing.
- Provides a barrier to water, moisture and gas — physically isolates the structure from the surrounding ground.
- BBA Certified for basement Grades 1, 2 & 3 as per BS 8102: 2009.
- Methane, carbon dioxide and radon gas protection in excess of the standard membrane requirements in BRE Reports 211 (Radon) and 212 (Methane and Carbon Dioxide).
- Independent Assessments
 - BBA Certificate No. 97/3325.
 - Mott MacDonald Special Services Report May 2001.
 - International Certifications.
- Zero permeance to moisture.
- Solar reflective — reduced temperature gain.
- Simple and quick to install, requiring no priming or fillets.
- Can be applied to permanent formwork — allows maximum use of confined sites.
- Self protecting — can be trafficked immediately after application and ready for immediate placing of reinforcement.
- Unaffected by wet conditions — cannot activate prematurely.
- Inherently waterproof, non-reactive system:
 - not reliant on confining pressures or hydration
 - unaffected by freeze/thaw, wet/dry cycling.
- Chemically resistant, effective in all types of soils and waters - protects structure from salt or sulphate attack.

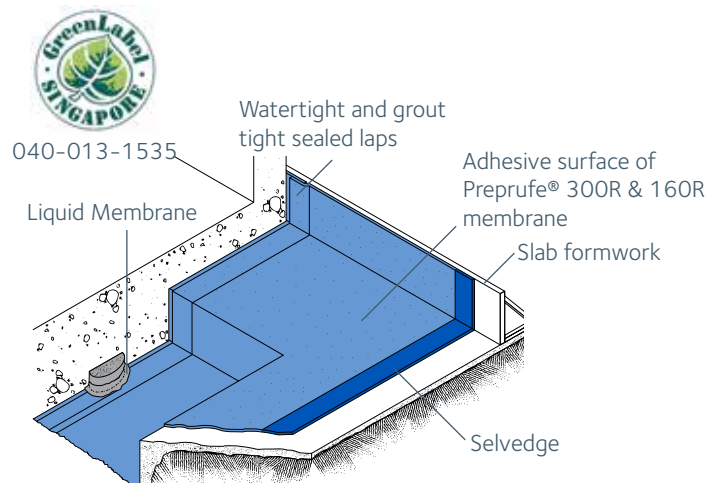

The Preprufe R System includes:

- Preprufe 300R — heavy-duty grade for use below slabs and on rafts (i.e. mud slabs). Designed to accept the placing of heavy reinforcement using conventional concrete spacers.
- Preprufe 160R — thinner grade for lighter applications and reverse tanking (i.e. blindside zero property line) applications against permanent formwork such as soil retention systems.
- Preprufe Tape LT — for covering cut edges, roll ends, penetrations and detailing (temperatures between -4°C and $+30^{\circ}\text{C}$).
- Preprufe Tape HC — as above for use in Hot Climates (minimum 10°C).
- Liquid Membrane — for sealing around penetrations, etc.
- Preprufe 300R & 160R membranes are applied either horizontally to smooth prepared concrete or well rolled and compacted sand or crushed stone blinding; or vertically to permanent formwork or adjoining structures. Concrete is then cast directly against the adhesive side of the membranes. The specially developed Preprufe adhesive layers work together to form a continuous and integral seal to the structure.
- Preprufe can be returned up the inside face of slab formwork but is not recommended for conventional twin-sided formwork on walls, etc. Use Bituthene® self-adhesive membrane or Silcor® membrane to walls after removal of formwork for a fully bonded system to all structural surfaces.

Installation

Preprufe® 300R & 160R membranes are supplied in rolls 1.2m wide, with a selvedge on one side to provide self-adhered laps for continuity between rolls. The rolls of Preprufe membrane and Preprufe Tape are interwound with a disposable plastic release liner which must be removed before placing reinforcement and concrete.

Substrate Preparation

All Surfaces — It is essential to create a sound and solid substrate to eliminate movement during the concrete pour. Substrates must be regular and smooth with no gaps or voids greater than 12mm. Grout around all penetrations such as utility conduits, etc. for stability.

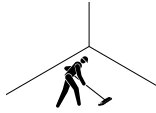

Horizontal Blinding — Monolithic concrete blinding or mud slab is preferred. The blinding must be free of loose aggregate and sharp protrusions. An angular profiled blinding is recommended rather than a sloping or rounded substrate. The surface does not need to be dry, but standing water must be removed.

Vertical Sheet Piling — Use concrete, plywood, insulation or other approved facing to sheet piling to provide support to the membrane. Board systems such as timber lagging must be close butted to provide support and not more than 12mm out of alignment.

Membrane Installation

Preprufe can be applied at temperatures of -4°C or above. During cold or damp conditions, the selvedge and tape adhesive can be gently warmed using a hot air gun or similar to remove moisture or condensation and improve initial adhesion.

Horizontal Substrates — Place the membrane HDPE film side to the substrate with printed coated side up facing towards the concrete pour. End laps should be staggered to avoid a build up of layers. Leave plastic release liner in position until overlap procedure is completed. Accurately position succeeding sheets to overlap the previous sheet 75mm along the marked selvedge. Ensure the underside of the succeeding sheet is clean, dry and free from contamination before attempting to overlap. Peel back the plastic release liner from between the overlaps as the two layers are bonded together. Ensure a continuous bond is achieved without creases and roll firmly with a heavy roller. Completely remove the plastic liner to expose the protective coating. Any initial tack will quickly disappear.



Vertical Substrates — Mechanically fasten the membrane vertically using fixings (i.e. fasteners) appropriate to the substrate with the printed coated side facing towards the concrete pour. The membrane may be installed in any convenient length. Secure the top of the membrane using a batten such as a termination bar or fixing 50mm below the top edge. Fixings can be made through the selvedge so that the membrane lays flat and allows firmly rolled overlaps. Immediately remove the plastic release liner. Any additional fixings must be covered with a patch of Preprufe Tape. Ensure the underside of the succeeding sheet is clean, dry and free from contamination before attempting to overlap. Roll firmly to ensure a watertight seal. Roll Ends and Cut Edges - Overlap all roll ends and cut edges by a minimum 75mm and ensure the area



is clean and free from contamination, wiping with a damp cloth if necessary. Allow to dry and apply Preprufe Tape LT (or HC in hot climates) centered over the lap and roll firmly. Immediately remove printed plastic release liner from the tape.

Penetrations

Use the following steps to seal around penetrations such as service pipes, piles, lightning conductors, etc. Grout around the penetration if the penetration is not stable. Scribe membrane tight to the penetration. If the membrane is not within 12mm of the penetration, apply Preprufe Tape to cover the gap. Wrap the penetration with Preprufe Tape by positioning the tape 12mm above the membrane.

Mix and apply Bituthene Liquid Membrane around the penetrations using a fillet to provide a watertight seal between the Preprufe membrane and Preprufe Tape.

Corners

Internal and external corners should be formed as shown in the diagrams returning the membrane a minimum of 100mm and sealing with Preprufe Tape. Ensure that the apex of the corner is covered and sealed with tape and roll firmly. Crease and fold the membrane to ensure a close fit to the substrate profile and avoid hollows.

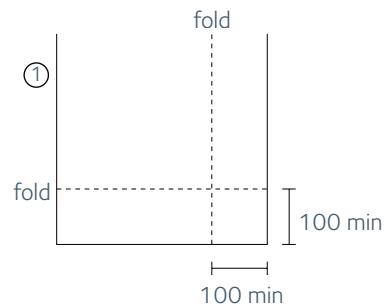

Internal

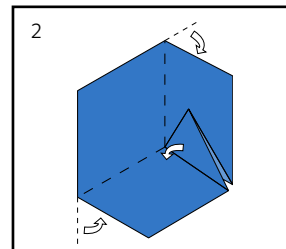

External

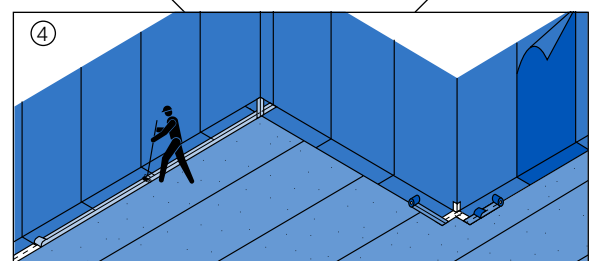
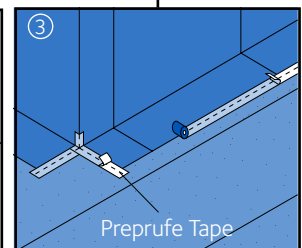
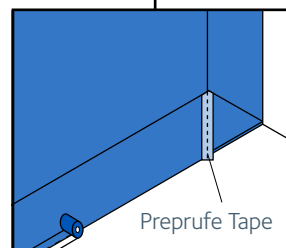
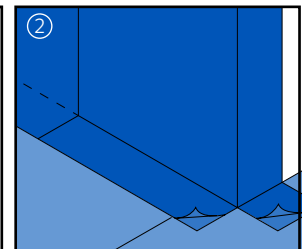

Membrane Repair

Inspect the membrane before installation of reinforcement steel, formwork and final placement of concrete. The membrane can be easily cleaned by jet washing if required. Repair damage by wiping the area with a damp cloth to ensure the area is clean and free from dust, and allow to dry. Apply Preprufe® Tape centered over the damaged area and roll firmly. Any areas of damaged adhesive should be covered with Preprufe Tape. Remove printed plastic release liner from tape. Where exposed selvedge has lost adhesion or laps have not been sealed, ensure the area is clean and dry and cover with fresh Preprufe Tape, rolling firmly. Alternatively, use a hot air gun or similar to activate adhesive and firmly roll lap to achieve continuity.

Pouring of Concrete

Ensure the plastic release liner is removed from all areas of Preprufe 300R & 160R membrane and Tape. It is recommended that concrete be poured within 56 days (42 days in hot climates) of application of the membrane. Concrete must be placed and compacted carefully to avoid damage to the membrane. Never use a sharp object to consolidate the concrete.

Removal of Formwork

Preprufe membranes can be applied to removable formwork, such as slab perimeters, elevator and lift pits, etc. Once the concrete is poured the formwork must remain in place until the concrete has gained sufficient compressive strength to develop

Wall base detail

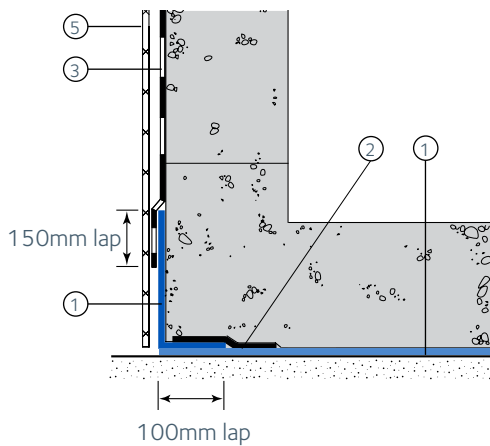

Alternative wall base detail for early shutter removal

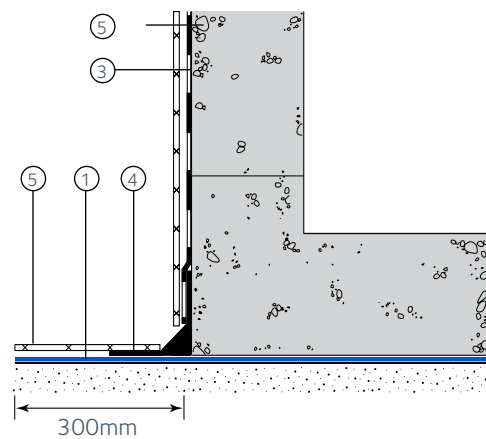

Wall base with toe detail showing drainage option

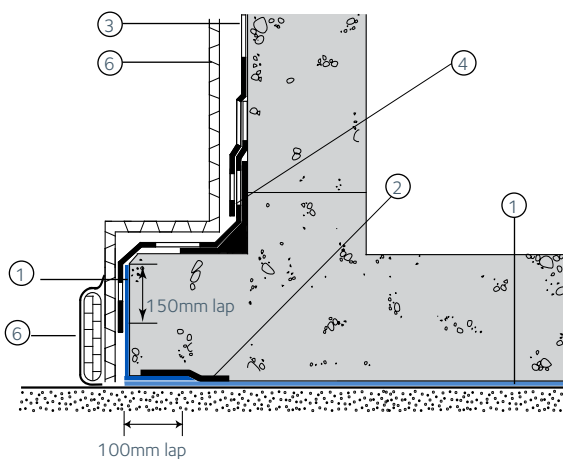

Wall base detail against permanent shutter

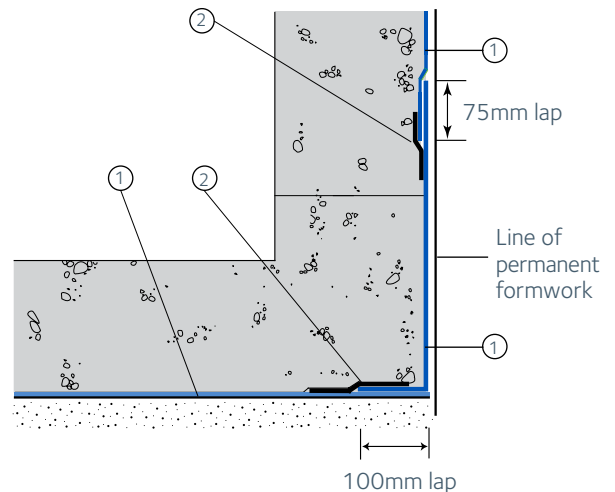

Pipe penetration

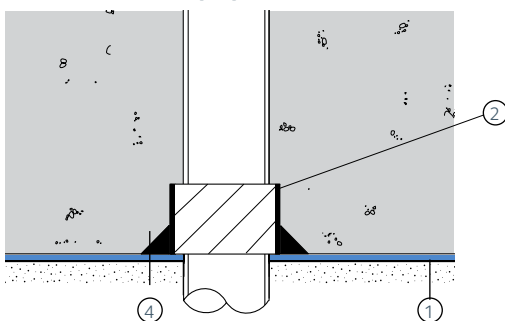

Pile detail

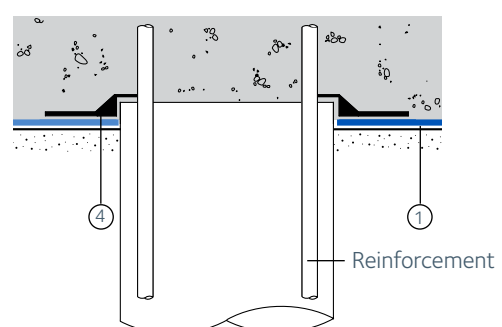

- | | | |
|------------------|----------------------|--------------|
| 1 Preprufe® | 3 Bituthene®/Silcor® | 5 Protection |
| 2 Preprufe® Tape | 4 Liquid Membrane | 6 Hydroduct® |

Details shown are typical illustrations and not working details. For assistance with detailing and problem solving please contact the Technical Department.

Physical Properties

Property	Typical Value		Test Method
	300R	160R	
Colour	White		
Thickness	1.2mm	0.8mm	ASTM D3767
Peel Adhesion to Concrete	880N/m		ASTM D903 modified
Resistance to Hydrostatic Head	>70m		ASTM D5385 modified
Low Temperature Flexibility	<-23 °C		ASTM D1970
Puncture Resistance	1000N	445N	ASTM E 154
Elongation	300% minimum		ASTM D412 modified
Tensile Strength, Film	27.6Mpa		ASTM D412
Crack Cycling @ -23 °C	Pass		ASTM C 836

Typical test values represent average values from samples tested. Test methods noted may be modified.

Supply

Preprufe	300R	160R	Tape LT or HC*
Thickness (Nominal)	1.2mm	0.8mm	-
Roll Size	1.2 x 30.0m	1.2 x 35.0m	100mm x 15.0m
Roll Area	36.0m ²	42m ²	-
Roll Weight	50kg	42kg	2kg
Min. Edge/End Laps	75mm	75mm	75mm
* LT denotes Low Temperature (between -4 °C and +30 °C) HC denotes Hot Climates (>+10 °C)			
Ancillary Products			
Liquid Membrane, 5.7L			

the surface bond. Preprufe® membranes are not recommended for conventional twin-sided wall forming systems.

A minimum concrete compressive strength of 10N/mm² (1500 psi) is recommended prior to stripping formwork supporting Preprufe membranes. Premature stripping may result in displacement of the membrane and/or spalling of the concrete.

As a guide, to reach the minimum compressive strength stated above, a structural concrete mix with an ultimate strength of 40N / mm² (6000psi) will typically require a cure time of approximately 6 days at an average ambient temperature of 4°C, or 2 days at 21°C.

Specification Clauses

Preprufe 300R or 160R shall be applied with its adhesive face presented to receive fresh concrete to which it will integrally bond. Only GCP Applied Technologies approved membranes shall be bonded to Preprufe 300R & 160R. All Preprufe 300R & 160R system materials shall be supplied by GCP Applied Technologies, and applied strictly in accordance with their instructions. Specimen performance and formatted clauses are also available.

Health and Safety

Refer to relevant Material Safety Data Sheet. Complete rolls should be handled by a minimum of two persons.

Technical Services

For assistance with working drawings for projects and additional technical advice, please contact your local GCP representative.

gcpat.com | For technical information: asia.enq@gcpat.com

Australia 1800 855 525 email: au.sbmsales@gcpat.com New Zealand +64 9 448 1146 China Mainland +86 21 3158 2888
Hong Kong +852 2675 7898 India +91 124 488 5900 Indonesia +62 21 893 4260 Japan +81 3 5226 0231 Korea +82 32 820 0800
Malaysia +60 3 9074 6133 Philippines +63 49 549 7373 Singapore +65 6265 3033 Thailand +66 2 709 4470 Vietnam +84 8 3710 6168

We hope the information here will be helpful. It is based on data and knowledge considered to be true and accurate, and is offered for consideration, investigation and verification by the user, but we do not warrant the results to be obtained. Please read all statements, recommendations, and suggestions in conjunction with our conditions of sale, which apply to all goods supplied by us. No statement, recommendation, or suggestion is intended for any use that would infringe any patent, copyright, or other third party right.

Preprufe, Bituthene, Silcor and Hydroduct are trademarks, which may be registered in the United States and/or other countries, of GCP Applied Technologies, Inc. This trademark list has been compiled using available published information as of the publication date and may not accurately reflect current trademark ownership or status.

© Copyright 2016 GCP Applied Technologies, Inc. All rights reserved.

GCP Applied Technologies Inc., 62 Whittemore Avenue, Cambridge, MA 02140, USA

Printed in Singapore | 02/17 | 300-Preprufe-5A



gcp applied technologies